

### REWIREABLE C13 IEC Lock+ Connector

#### Technical, Safety, and Installation Details

Please read the following information carefully before commencing installation.

Before commencing any electrical work, to prevent the possibility of receiving an electric shock, ensure the mains isolator on the consumer unit / fuse board is in the 'OFF' Position.

This product is rated to 10A (EU), 15A (USA/Canada) at 250V~ 50Hz and 60Hz.

To access the terminations, first remove handle (Fig. 1-3.), remove the fixing screws (Fig. 4.), and then remove the outer housing and cord grip (Fig. 5.).

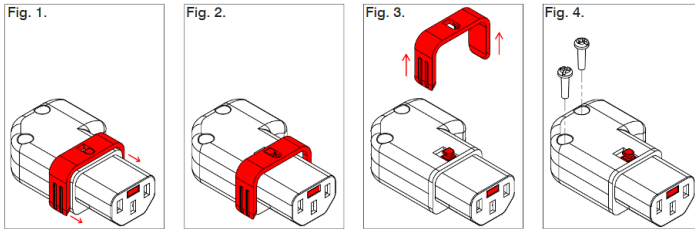

Wire the cable into the terminal (Fig. 6.) ensuring correct polarity and nominal torques values are observed (0.4Nm).

Strip cable outer jacket to length (ensuring GROUND is longer than HOT/LIVE and NEUTRAL).

- Both HOT/LIVE and NEUTRAL = 18mm (11/16")
- EARTH (Ground) = 23mm (15/16")

| Color Code Chart   |                       |              |
|--------------------|-----------------------|--------------|
|                    | NA                    | CEE          |
| <b>N - NEUTRAL</b> | White                 | Light Blue   |
| <b>L - LIVE</b>    | Black                 | Brown        |
| <b>G - GROUND</b>  | Green or Green/Yellow | Green/Yellow |

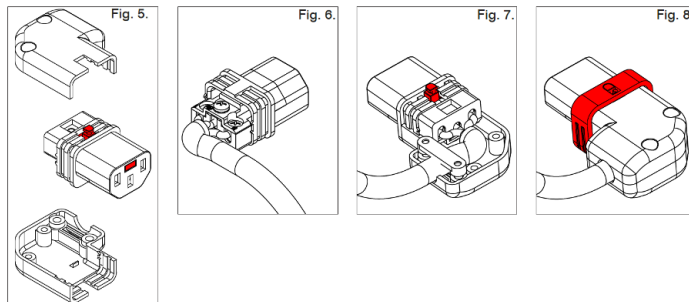

Replace the cord grip (Fig. 7.) ensuring the torque value is achieved (0.3Nm), and then replace the outer housing, screws and handle (Fig. 8.).

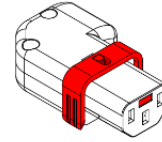

### REWIREABLE C13 IEC Lock+ Connector

#### Technical, Safety, and Installation Details

Please read the following information carefully before commencing installation.

Before commencing any electrical work, to prevent the possibility of receiving an electric shock, ensure the mains isolator on the consumer unit / fuse board is in the 'OFF' Position.

This product is rated to 10A (EU), 15A (USA/Canada) at 250V~ 50Hz and 60Hz.

To access the terminations, first remove handle (Fig. 1-3.), remove the fixing screws (Fig. 4.), and then remove the outer housing and cord grip (Fig. 5.).

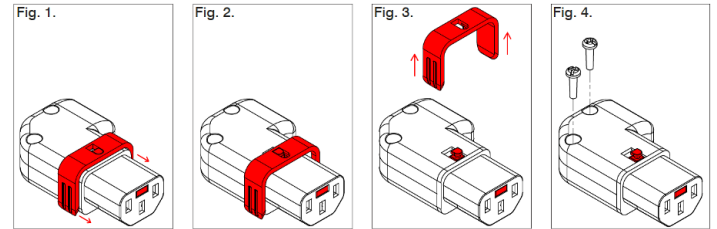

Wire the cable into the terminal (Fig. 6.) ensuring correct polarity and nominal torques values are observed (0.4Nm).

Strip cable outer jacket to length (ensuring GROUND is longer than HOT/LIVE and NEUTRAL).

- Both HOT/LIVE and NEUTRAL = 18mm (11/16")
- EARTH (Ground) = 23mm (15/16")

| Color Code Chart   |                       |              |
|--------------------|-----------------------|--------------|
|                    | NA                    | CEE          |
| <b>N - NEUTRAL</b> | White                 | Light Blue   |
| <b>L - LIVE</b>    | Black                 | Brown        |
| <b>G - GROUND</b>  | Green or Green/Yellow | Green/Yellow |

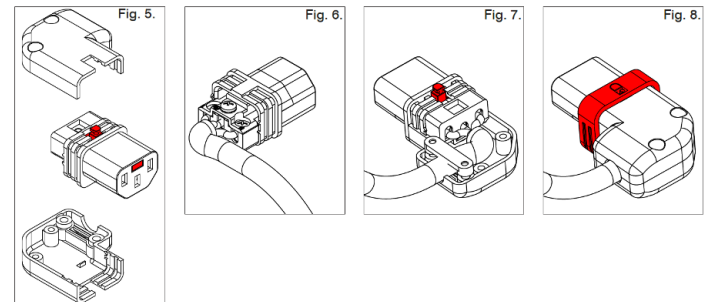

Replace the cord grip (Fig. 7.) ensuring the torque value is achieved (0.3Nm), and then replace the outer housing, screws and handle (Fig. 8.).

## CHANGING THE ORIENTATION to RIGHT or LEFT

1. Remove the handle from the connector by sliding forward and pulling away from the connector (Fig. 9-11.).
2. Remove fixing screws from housing (Fig. 12.).

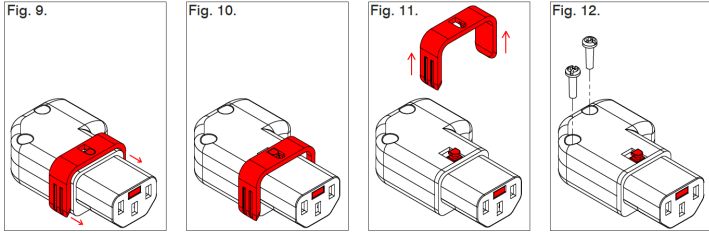

3. Remove the top and bottom outer housing (Fig. 13.).
4. Switch orientation and replace outer housing. The top housing should now be on the bottom and vice versa (Fig. 14. & 15.).
5. Once the outer housing has been replaced, the handle can be replaced (Fig. 16.).

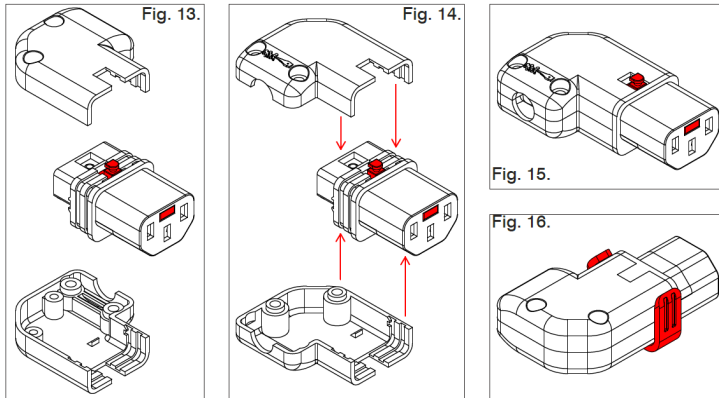

### 250V

CSAC22.2 No. 60320-1-11. Standard for Appliance Couplers for Household and Similar General Purposes - Part 1: General Requirements - Edition 1 - Issue Date 05/12/2011  
 UL 60320-1 Appliances Couplers for Similar General Purposes - Part 1: General Requirements - Edition 2 - Issue Date 05/12/2011  
 IEC 60320-2-2:1998 (2nd Edition) used in conjunction with IEC 60320-1:2001 (2nd Edition)  
 EN 60320-2-2:1998 (2nd Edition) used in conjunction with EN 60320-2:2001

### SYSTEM DESCRIPTION

Screw-In Terminals – This product is designed to be used in accordance with cords with rating no higher than that of the product itself.  
 The nominal torque value for the terminal screws = 0.4Nm. The strain relief clamping screws should be tightened to 0.3Nm (2.65in-lbs).

### INSERTION AND REMOVAL

It is essential for maintaining the service life of the product, specifically the locking blade and it's locking properties that the following is adhered to.

Before inserting / removing the connector from a C13 Socket, the locking blade mechanism must be disengaged by fully retracting the RED handle (Fig. 18.) (Fig. 19.).

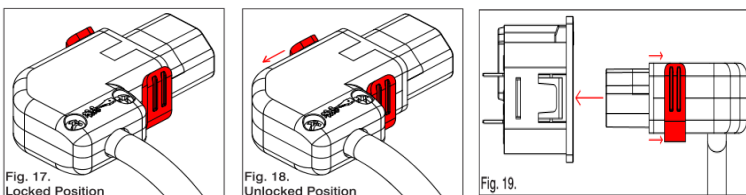

## CHANGING THE ORIENTATION to RIGHT or LEFT

1. Remove the handle from the connector by sliding forward and pulling away from the connector (Fig. 9-11.).
2. Remove fixing screws from housing (Fig. 12.).

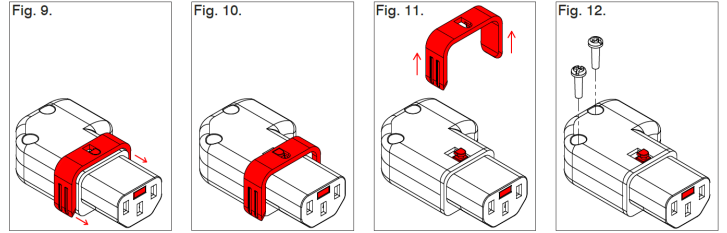

3. Remove the top and bottom outer housing (Fig. 13.).
4. Switch orientation and replace outer housing. The top housing should now be on the bottom and vice versa (Fig. 14. & 15.).
5. Once the outer housing has been replaced, the handle can be replaced (Fig. 16.).

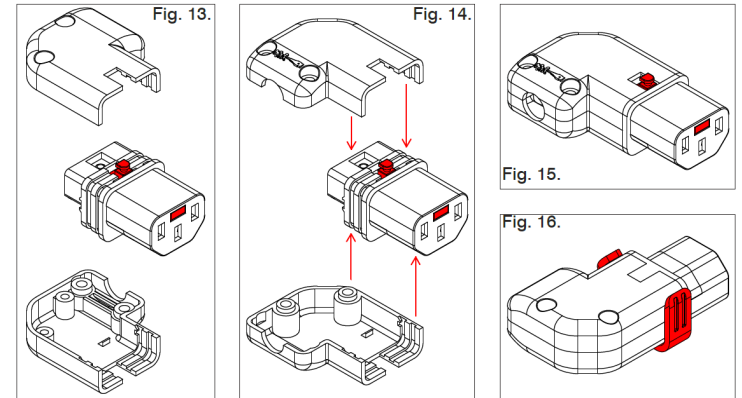

### 250V

CSAC22.2 No. 60320-1-11. Standard for Appliance Couplers for Household and Similar General Purposes - Part 1: General Requirements - Edition 1 - Issue Date 05/12/2011  
 UL 60320-1 Appliances Couplers for Similar General Purposes - Part 1: General Requirements - Edition 2 - Issue Date 05/12/2011  
 IEC 60320-2-2:1998 (2nd Edition) used in conjunction with IEC 60320-1:2001 (2nd Edition)  
 EN 60320-2-2:1998 (2nd Edition) used in conjunction with EN 60320-2:2001

### SYSTEM DESCRIPTION

Screw-In Terminals – This product is designed to be used in accordance with cords with rating no higher than that of the product itself.  
 The nominal torque value for the terminal screws = 0.4Nm. The strain relief clamping screws should be tightened to 0.3Nm (2.65in-lbs).

### INSERTION AND REMOVAL

It is essential for maintaining the service life of the product, specifically the locking blade and it's locking properties that the following is adhered to.

Before inserting / removing the connector from a C13 Socket, the locking blade mechanism must be disengaged by fully retracting the RED handle (Fig. 18.) (Fig. 19.).

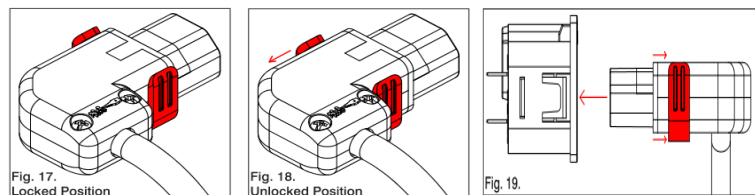

**WebberElectronics®**

38887 Taylor Pkwy, N. Ridgeville, OH 44039  
 440.327.7200

IECLock@WebberElectronics.com  
 WebberElectronics.com

**WebberElectronics®**

38887 Taylor Pkwy, N. Ridgeville, OH 44039  
 440.327.7200

IECLock@WebberElectronics.com  
 WebberElectronics.com