

Wiring Instructions

1. Cable Selection: Provide a cable of applicable ampacity, service, and temperature rating suitable for the conditions of use and location. The plugs and connectors are designed for use with 3-wire cables with a diameter from .300" to .480" (18/3 SJ through 12/3 S).

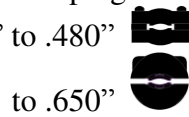

2. Cable Prep: Feed the cable end through the housing and strip the cord as shown in Figure 1 below. Make sure the wire is clean, and a bright copper color. Do not solder the ends of the wire.

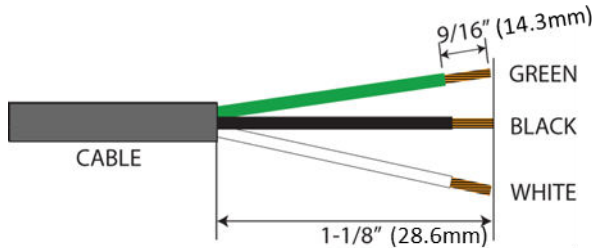











FIGURE 1





- 3. Assembly:** Select the proper plug or connector for your application. Loosen the 2 screws from the face and remove the assembly from the outer body. Insert the green wire into the terminal with the green colored screw. (Also marked "GR")
- For 125V devices, insert the white (neutral) wire into the terminal with the silver colored screw. (Also marked "W") Insert the black (hot) wire into the terminal with the black colored screw.
 - For 250V devices, insert black and white wires into terminals with black colored screws.

When making connections, make certain they are secure, properly insulated, and there are no stray wire strands outside the terminals. Tighten the terminal screws to 8.5~10 in-lbs torque.

Assemble the housing over the device body; the keyway in the housing and the body properly aligns the two parts. Tighten the cord clamp screws to a maximum 8-10 in-lbs torque. Lastly tighten the 2 assembly screws.

4. Configuration Chart:

| 15 Ampere Configuration Chart | | | | | |
|-------------------------------|---|--|--|--|--|
| | Straight Type | | Locking Type | | |
| Voltage | 125V | 250V | 125V | 250V | 277V |
| Plug |  5-15 |  6-15 |  L5-15 |  L6-15 |  L7-15 |
| Connector |  5-15 |  6-15 |  L5-15 |  L6-15 |  L7-15 |

| 20 Ampere Straight Type Configuration Chart | | | |
|---|---|---|---|
| 125V | | 250V | |
| Plug | Connector | Plug | Connector |
|  5-20 |  5-20 |  6-20 |  6-20 |